



DATE 18 March, 2015

No. V-70033C

Messrs. _____

SPECIFICATION

Semiconductor Pressure Sensor - Standard Product

Model: AP4, AG4 Pressure Sensor

Project: _____

Distributor: _____

Reference: _____

A handwritten signature in black ink, appearing to read 'Y. Uchiumi'.

Yoshiyuki Uchiumi, Application Engineer
Sensor Department Fujikura Ltd.

Fujikura Ltd.

Table of Contents

1. General	2
2. Principle	2
3. Device Lineup.....	2
4. RoHS.....	2
5. Block Diagram and Pin Connections.....	3
6. Device Name Code.....	4
7. Absolute Maximum Ratings.....	5
8. General Specifications	5
9. Electrical Characteristics.....	6
10. Communication Interface.....	7
11. Communication Protocol.....	8
12. Output versus Input Pressure.....	9
13. Transfer Function.....	10
14. Operating Sequence	10
15. Device Marking	11
16. Soldering	12
17. Dimensions and Weights.....	12
18. Ordering Information	13
19. Tape & Reel Information	13
20. Footprint for PCB (for Reference).....	14
21. Notes.....	15
Appendix: Dimension Drawing	16
9-772-001 APxxN	16
9-772-002 APxxR	17
9-772-003 AGxx3	18
9-772-004 AGxx6.....	19

Table shown below is revision records of this specification

Rev. C	18 Mar., 2015	Y. Uchiumi	Change arrangement of Slave address code and Custom ID	C
Rev. B	7 Jan., 2015	Y Uchiumi	Added 700kPa(700KG).	B
Rev. A	29 July, 2014	Y Uchiumi	Correction 10. Communication Interface	A
Est.	15 May, 2014	Y Uchiumi		
	Date	Name	Comment	Mark

1. General

This document describes the specifications of Fujikura Pressure Sensors, AP4 and AG4 series.

2. Principle

Fujikura Pressure Sensor is composed of a silicon piezoresistive pressure sensing chip and a signal conditioning integrated circuit. The low-level signal from the sensing chip is amplified, temperature compensated, calibrated, and finally converted to digital data that is proportional to the applied pressure.

3. Device Lineup

This device has the following lineup.

Model	Pressure Type	Supply Voltage	Accuracy	Pressure Range													
				-100	-50	0	25	50	100	200	500	700	1000	kPa			
				(-15)	(-7)		(3)	(7)	(15)	(30)	(70)	(100)	(150)	psi			
AP4 or AG4	Gauge	5.0 Vdc 3.3 Vdc 3.0 Vdc	±1.5 %FS			025KG											
						050KG											
						100KG											
						200KG											
						500KG											
						700KG											
						001MG											
						050KV											
						100KV											
						100KW											

Features

- ✓ Digital output
- ✓ Low power consumption
- ✓ High accuracy
- ✓ Package compatible with XFPM & XFGM integrated pressure sensor
- ✓ Modification available

Applications

- ✓ Battery-operated devices
- ✓ Medical devices
- ✓ Industrial pneumatic devices
- ✓ Consumer devices

4. RoHS

This device is compliant with the Restriction of the use of certain Hazardous Substances in Electrical and Electronic Equipment (RoHS).

5. Block Diagram and Pin Connections

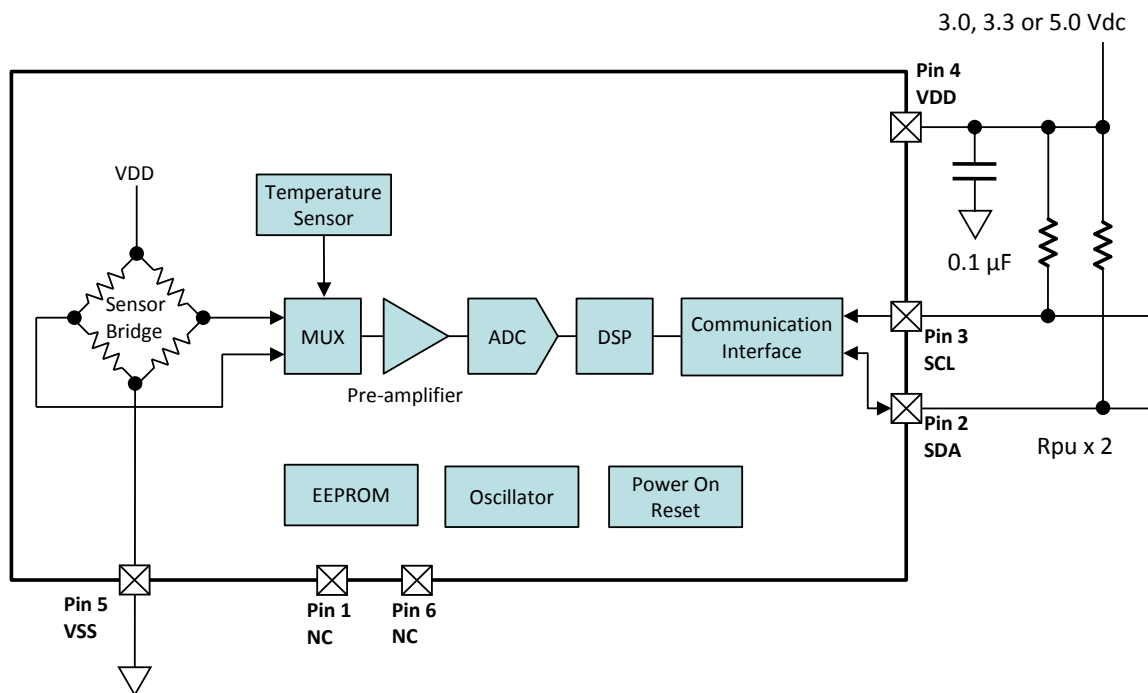

Pin Assignment		Pin No.	Pin Name	I/O	Type	Function	
AP4	AG4						
		1	NC	-	-	-	*2
		2	SDA	I/O	Digital	Serial bidirectional data	
		3	SCL	I	Digital	Serial clock input	
		4	VDD	-	-	Power supply connection	*1
		5	VSS	-	-	Common voltage connection	
		6	NC	-	-	-	*2

Notes:

*1) Put a 0.1 µF capacitor between Pin 4 (VDD) and VSS.

*2) Pin 1 and 6 must be open.

6. Device Name Code 

The device name code is consisted of Sensor code, Pressure code, Slave address code and Packing style. For the exact ordering device number, please refer to Chapter 18 Ordering Information.

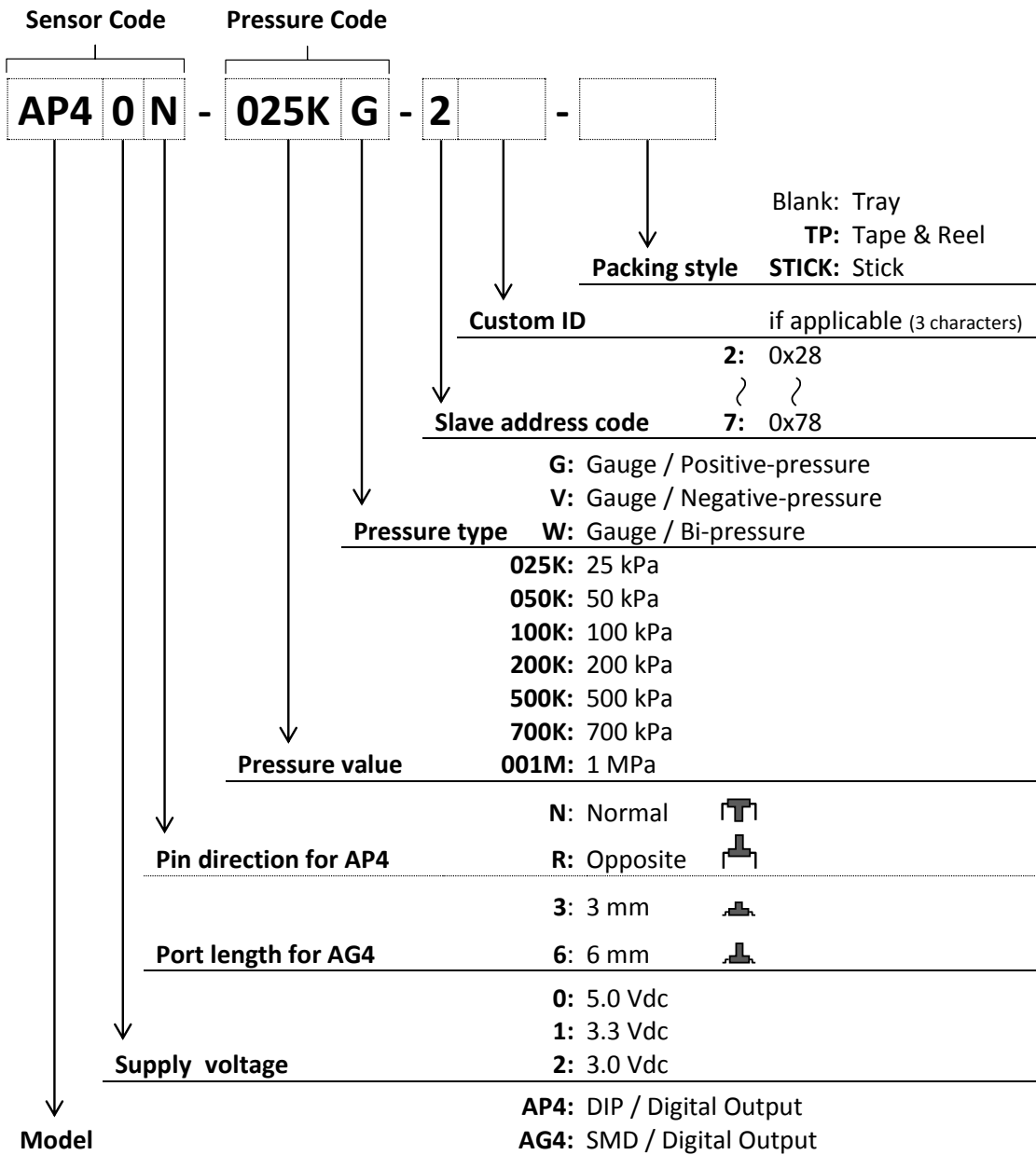

V-70033C

7. Absolute Maximum Ratings

Item		Symbol	Rating			Unit
			Min.	Typ.	Max.	
Load Pressure	Pressure Code	025KG	-	-	+50	kPa
		050KG	-	-	+100	kPa
		100KG	-	-	+200	kPa
		200KG	-	-	+400	kPa
		500KG	-	-	+1	MPa
		700KG	-	-	+1.4	MPa
		001MG	-	-	+1.5	MPa
		050KV	-	-	+100	kPa
		100KV	-	-	+200	kPa
	100KW	-	-	+200	kPa	
Supply Voltage		VDDmax	-0.3	-	6	Vdc
Voltage at Digital I/O pins		Vdiomax	-0.3	-	VDD+0.3	Vdc
Operating Temperature		Topt	-40	-	+125	deg. C
Storage Temperature		Tstg	-40	-	+125	deg. C

Note: Absolute maximum ratings are the limits that the device will withstand without damage.

8. General Specifications

Item		Condition	Symbol	Rating			Unit
				Min.	Typ.	Max.	
Supply Voltage	Sensor Code	AP40x, AG40x	VDD	4.75	5	5.25	Vdc
		AP41x, AG41x		3.135	3.3	3.465	
		AP42x, AG42x		2.85	3.0	3.15	
Type of Pressure		-	Gauge pressure				
Pressure Media		-	Non-corrosive gases				
Pressure Range	Pressure Code	025KG	Popt	0	-	+25	kPa
		050KG		0	-	+50	kPa
		100KG		0	-	+100	kPa
		200KG		0	-	+200	kPa
		500KG		0	-	+500	kPa
		700KG		0	-	+700	kPa
		001MG		0	-	+1	MPa
		050KV		-50	-	0	kPa
		100KV		-100	-	0	kPa
	100KW	-100	-	+100	kPa		
Compensated Temperature		-	0	-	+85	deg. C	
Operating Humidity	Non-condensing	Hopt	30	-	85	%RH	
Storage Humidity	Non-condensing	Hstg	30	-	85	%RH	
Dielectric Strength			-	-	1	mA	
Insulation Resistance			100	-	-	MΩ	

Notes:

- *1) Supply voltage (VDD) should be constant.
- *2) Gauge pressure is defined as the difference between applied pressure to the pressure port and atmospheric pressure of the device.
- *3) Ensure the pressure media contains no particulates. The device is not compatible with liquids.
- *4) Pressure range is defined as the measurable pressure range of the device. Do not expose intentionally beyond minimum Popt and maximum Popt.
- *5) Please also refer to Chapter 13 Transfer Function.
- *6) Do not wet the device with dew.
- *7) Dielectric strength is defined as the leakage current between all pins and the package with AC 500 V, 1 minute.
- *8) Insulation resistance is defined as the resistance value between all pins and the package with DC 500 V.

9. Electrical Characteristics

Ambient temperature $T_a=25\text{deg. C}$

Item	Condition	Symbol	Rating			Unit	
			Min.	Typ.	Max.		
Offset Pressure Data	Min. Popt, 050KV, 100KV: Max. Popt	Doff	598	819	1040	Count	*1, 2
Full Scale Pressure Data	Max. Popt, 050KV, 100KV: Min. Popt	Dfs	15344	15565	15786	Count	*3
Span Pressure Data	Min. to max. Popt	SD	-	14746	-	Count	*4
Accuracy	0 to 85 deg. C	Error	-1.5	-	+1.5	%FS	*5, 6
Supply Current	VDD = 5 Vdc	Ic	-	-	4.5	mAdc	*7
	VDD = 3.3, 3.0 Vdc		-	-	3.5		
Response Time	for reference	tr	-	1	-	msec.	*8

Notes:

- *1) Offset pressure data (Doff) is defined as the pressure data at minimum Popt. In case of 050KV and 100KV, Offset pressure data (Doff) is defined as the pressure data of maximum Popt.
- *2) Offset error is calibration error of Offset pressure data (Doff) at production. It does not include Long term offset drift. It would be suggested that applications have Auto-zeroing function.
- *3) Full scale pressure data (Dfs) is defined as the pressure data at maximum Popt. In case of 050KV and 100KV, Full scale pressure data (Dfs) is defined as the pressure data of minimum Popt.
- *4) Span pressure data (SD) is defined as the pressure data difference between Offset pressure data (Doff) and Full scale pressure data (Dfs).
- *5) Accuracy consists of the following:
 - Non-linearity
 - Temperature errors over the temperature range 0 to 85 degree C
 - Pressure hysteresis
 - Calibration errors of sensitivity and offset
- *6) The unit of Accuracy "%FS" is defined as a percent error by Span pressure data (SD).
- *7) We can offer lower power mode products as modification line. Please ask to Fujikura.
- *8) Response time (tr) is defined as the time for the change in the pressure data from 10 % to 90 % or from 90 % to 10 % of its final value when the input pressure makes a step change.

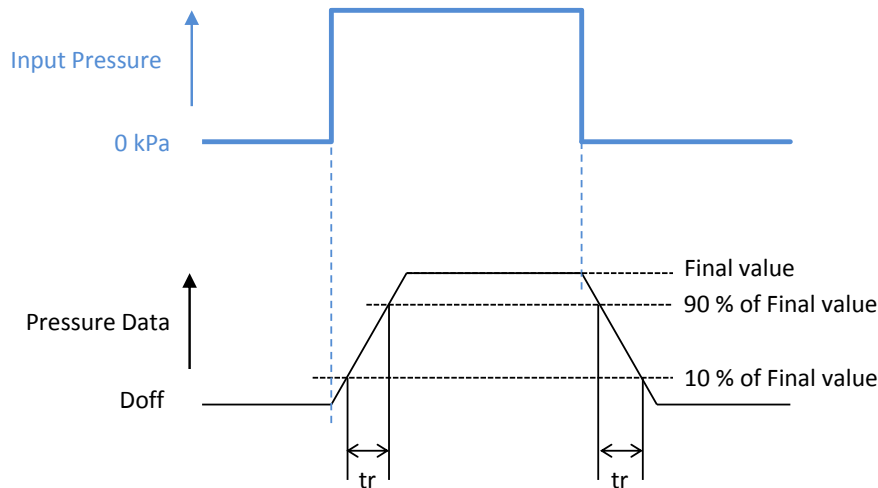

11. Communication Protocol

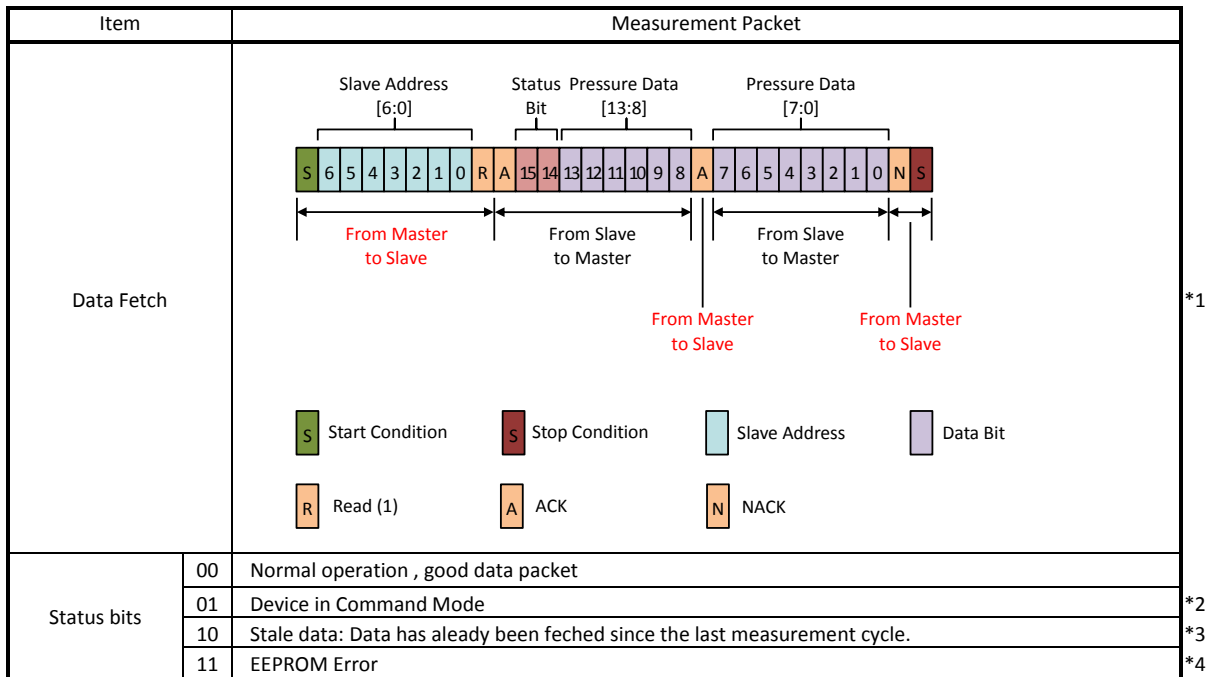

Note:

- *1) Temperature data fetch is available after pressure data. For more information, please ask Fujikura.
- *2) If the status bits are 01, the device must be re-started to turn power supply off and on again.
- *3) If a data fetch is performed before or during the first measurement after power-on reset, then “stale” will be returned, but this data is actually invalid because the first measurement has not been completed.
- *4) If the status bits are 11, do not use the device anymore.

12. Output versus Input Pressure

Pressure Code	Output vs. Input pressure
025KG 050KG 100KG 200KG 500KG 700KG 001MG	<p style="text-align: center;">Temp. = 0 to 85°C</p> <p style="text-align: center;">Input Pressure</p>
050KV 100KV	<p style="text-align: center;">Temp. = 0 to 85°C</p> <p style="text-align: center;">Input Pressure</p>
100KW	<p style="text-align: center;">Temp. = 0 to 85°C</p> <p style="text-align: center;">Input Pressure</p>

13. Transfer Function

$$\text{Pressure Data (Count)} = P \times \alpha + \beta \pm (\text{Pressure Error} \times \text{Temperature Error Multiplier})$$

Parameters

Parameter Pressure Code	P (kPa)	α	β	Pressure Error (Count)
025KG	0 ~ +25	14746/25	819	221
050KG	0 ~ +50	7373/25	819	221
100KG	0 ~ +100	7373/50	819	221
200KG	0 ~ +200	7373/100	819	221
500KG	0 ~ +500	7373/250	819	221
700KG	0 ~ +700	7373/350	819	221
001MG	0 ~ +1000	7373/500	819	221
050KV	-50 ~ 0	-7373/25	819	221
100KV	-100 ~ 0	-7373/50	819	221
100KW	-100 ~ +100	7373/100	8192	221

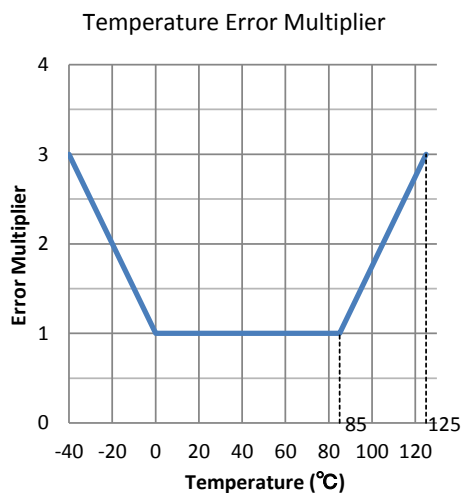

14. Operating Sequence

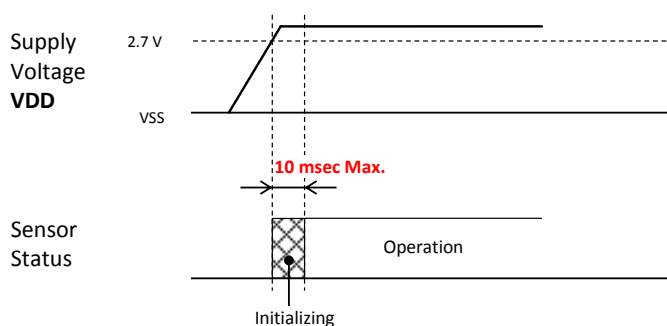

15. Device Marking

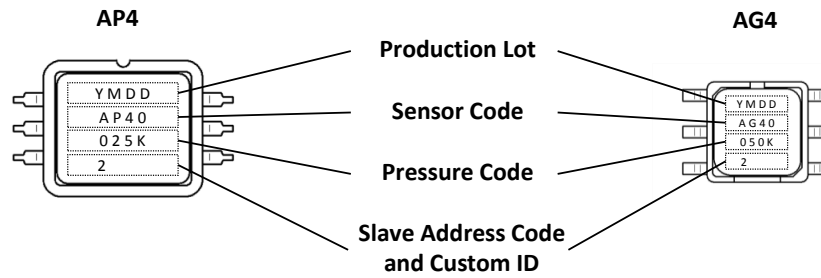

Items		Marking
Production Lot		
Y	Last digit of Production year	0~9
M	Production month	1, 2, 3 ~ 8, 9, X=Oct., Y=Nov., Z=Dec.
DD	Production date	01~31
Sensor Code		
	AP40x	AP40
	AP41x	AP41
	AP42x	AP42
	AG40x	AG40
	AG41x	AG41
	AG42x	AG42
Pressure Code		
	025KG	025K
	050KG	050K
	100KG	100K
	200KG	200K
	500KG	500K
	700KG	700K
	001MG	001M
	050KV	050V
	100KV	100V
	100KW	100W
Slave Address Code		
	2	2
	3	3
	4	4
	5	5
	6	6
	7	7
Custom ID		If applicable

*1

*2

Notes:

- *1) Pin direction for AP4 or Port length for AG4 is not marked on the face plate.
- *2) Custom ID will be added when product is customized for a customer.

16. Soldering

Process	Sensor code	Condition																		
Hand Soldering	AP4xx	Soldering iron temperature: 350 deg. C max. Soldering time: 3 seconds max.																		
Wave Soldering	AP4xR	Soldering bath temperature: 260 deg. C max. Soldering time: 5 seconds max.																		
Reflow Soldering	AG4xx	<p style="text-align: center;">Soldering Profile</p> <table border="1" style="margin-top: 10px;"> <thead> <tr> <th></th> <th></th> <th></th> </tr> </thead> <tbody> <tr> <td>A</td> <td>Ramp up</td> <td>2 to 4 deg. C / sec.</td> </tr> <tr> <td>B</td> <td>Pre-heating</td> <td>150 to 180 deg. C 60 to 120 sec.</td> </tr> <tr> <td>C</td> <td>Ramp up</td> <td>2 to 4 deg. C / sec.</td> </tr> <tr> <td>D</td> <td>Heating</td> <td>Above 230 deg. C, 45 sec. max. 245 deg. C max., 10 sec. max.</td> </tr> <tr> <td>E</td> <td>Ramp down</td> <td>2 to 4 deg. C / sec.</td> </tr> </tbody> </table>				A	Ramp up	2 to 4 deg. C / sec.	B	Pre-heating	150 to 180 deg. C 60 to 120 sec.	C	Ramp up	2 to 4 deg. C / sec.	D	Heating	Above 230 deg. C, 45 sec. max. 245 deg. C max., 10 sec. max.	E	Ramp down	2 to 4 deg. C / sec.
A	Ramp up	2 to 4 deg. C / sec.																		
B	Pre-heating	150 to 180 deg. C 60 to 120 sec.																		
C	Ramp up	2 to 4 deg. C / sec.																		
D	Heating	Above 230 deg. C, 45 sec. max. 245 deg. C max., 10 sec. max.																		
E	Ramp down	2 to 4 deg. C / sec.																		

*1, 2
*1, 2
*1, 2
3, 4

Notes:

- *1) NEVER wash the device with any washing liquid. NEVER wash the device with any ultrasonic washing machine.
- *2) Do not put the solder and flux on the device's package.
- *3) Temperature means Surface temperature of the device's package.
- *4) Do not reflow more than twice.

17. Dimensions and Weights

Refer to the following drawing as attached.

Sensor Code	Dimension Drawing	Weight
AP4xN	9-772-001	approx. 1.4 grams
AP4xR	9-772-002	
AG4x3	9-772-003	approx. 0.3 grams
AG4x6	9-772-004	approx. 0.4 grams

18. Ordering Information

Model	Package	Supply Voltage	Pin Direction	Packing	Ordering Device Number	Qty./Packing	
AP4	DIP	5.0 Vdc	Normal	Tray	AP40N- [Pressure Code] -[Slave]	150 Pcs/Tray	
				Stick	AP40N- [Pressure Code] -[Slave] -STICK	40 Pcs/Stick	
			Opposite	Tray	AP40R- [Pressure Code] -[Slave]	150 Pcs/Tray	
				Stick	AP40R- [Pressure Code] -[Slave] -STICK	40 Pcs/Stick	
			3.3 Vdc	Normal	Tray	AP41N- [Pressure Code] -[Slave]	150 Pcs/Tray
					Stick	AP41N- [Pressure Code] -[Slave] -STICK	40 Pcs/Stick
		Opposite	Tray	AP41R- [Pressure Code] -[Slave]	150 Pcs/Tray		
			Stick	AP41R- [Pressure Code] -[Slave] -STICK	40 Pcs/Stick		
		3.0 Vdc	Normal	Tray	AP42N- [Pressure Code] -[Slave]	150 Pcs/Tray	
				Stick	AP42N- [Pressure Code] -[Slave] -STICK	40 Pcs/Stick	
			Opposite	Tray	AP42R- [Pressure Code] -[Slave]	150 Pcs/Tray	
				Stick	AP42R- [Pressure Code] -[Slave] -STICK	40 Pcs/Stick	
			Port Length				
AG4	SMD		5.0 Vdc	3 mm	Tray	AG403- [Pressure Code] -[Slave]	300 Pcs/Tray
		Tape & Reel			AG403- [Pressure Code] -[Slave] -TP	500 Pcs/Reel	
		6 mm		Tray	AG406- [Pressure Code] -[Slave]	300 Pcs/Tray	
				Tape & Reel	AG406- [Pressure Code] -[Slave] -TP	500 Pcs/Reel	
		3.3 Vdc		3 mm	Tray	AG413- [Pressure Code] -[Slave]	300 Pcs/Tray
					Tape & Reel	AG413- [Pressure Code] -[Slave] -TP	500 Pcs/Reel
			6 mm	Tray	AG416- [Pressure Code] -[Slave]	300 Pcs/Tray	
				Tape & Reel	AG416- [Pressure Code] -[Slave] -TP	500 Pcs/Reel	
			3.0 Vdc	3 mm	Tray	AG423- [Pressure Code] -[Slave]	300 Pcs/Tray
					Tape & Reel	AG423- [Pressure Code] -[Slave] -TP	500 Pcs/Reel
		6 mm		Tray	AG426- [Pressure Code] -[Slave]	300 Pcs/Tray	
				Tape & Reel	AG426- [Pressure Code] -[Slave] -TP	500 Pcs/Reel	

Pressure Range	Pressure Code
0 ~ +25 kPa	025KG
0 ~ +50 kPa	050KG
0 ~ +100 kPa	100KG
0 ~ +200 kPa	200KG
0 ~ +500 kPa	500KG
0 ~ +700 kPa	700KG
0 ~ +1 MPa	001MG
-50 ~ 0 kPa	050KV
-100 ~ 0 kPa	100KV
-100 ~ +100 kPa	100KW

Slave Address	Slave Address Code
0x28	2
0x38	3
0x48	4
0x58	5
0x68	6
0x78	7

19. Tape & Reel Information

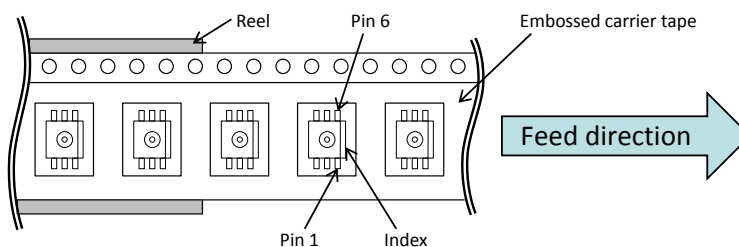

20. Footprint for PCB (for Reference)

Sensor Code	Footprint
AP4xN	
AP4xR	
AG4x3	
AG4x6	

Notes:

- *1) These footprints are for reference. Please evaluate well these footprints, before your mass production.
- *2) When designing your PCB, please also refer to the outline diagrams.

21. Notes

- Fujikura reserves all rights.
- This document is subject to change without notice.
- Limitation, usage, environment, standard warranty and so on are listed on Fujikura web site.
- Please refer to the latest specifications.



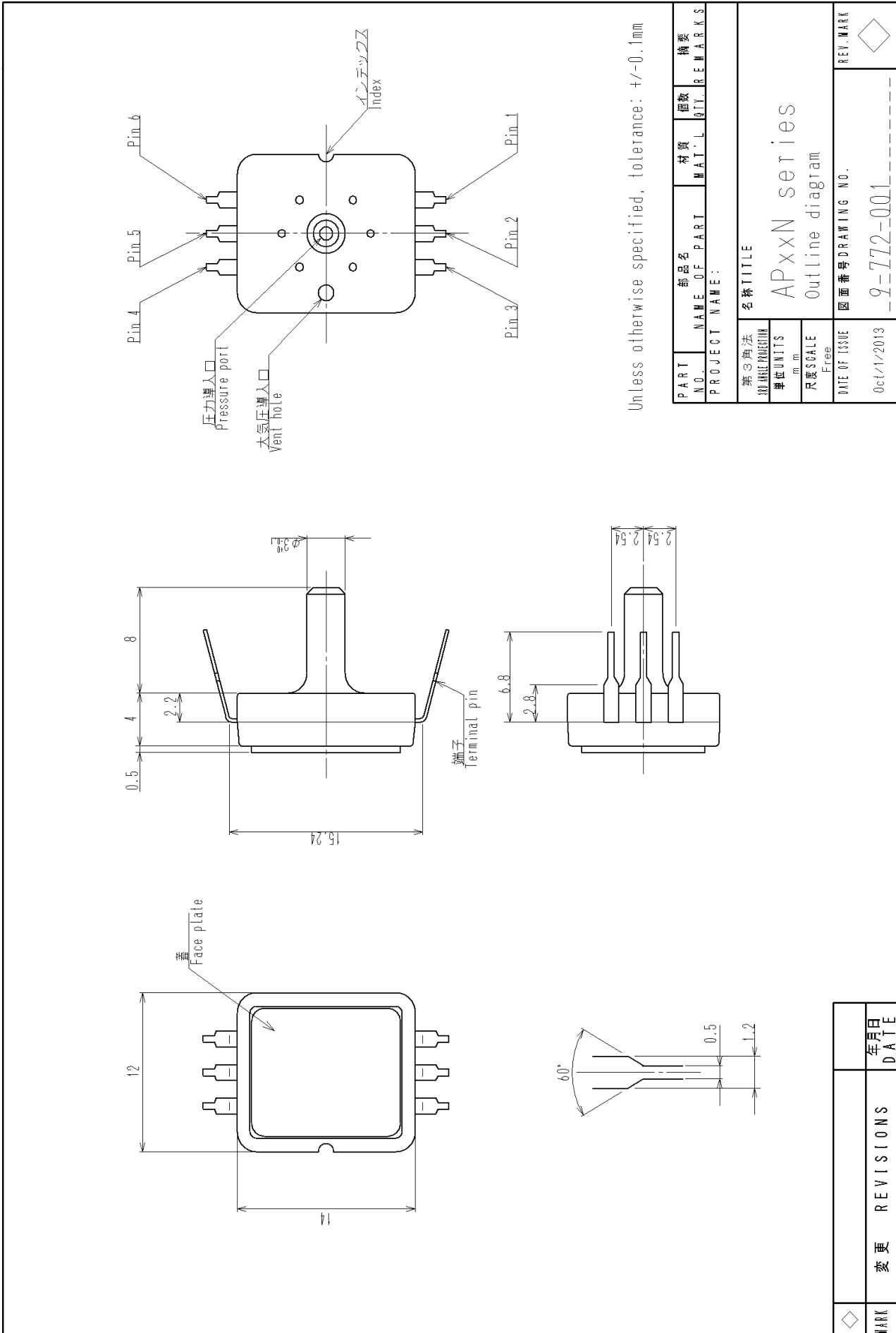

Unless otherwise specified, tolerance: +/-0.1mm

PART NO.	部品名	材質	個数	摘要
PROJECT NAME:				
名称 TITLE				
APxxN series				
Outline diagram				
第3角法				
SYMBOL POSITION				
単位 UNITS				
m.m				
尺度 SCALE				
Free				
DATE OF ISSUE				
Oct/1/2013				
図面番号 DRAWING NO.				
9-772-001				
REV. MARK				
◇				

MARK	変更 REVISIONS	年月日 DATE
◇		

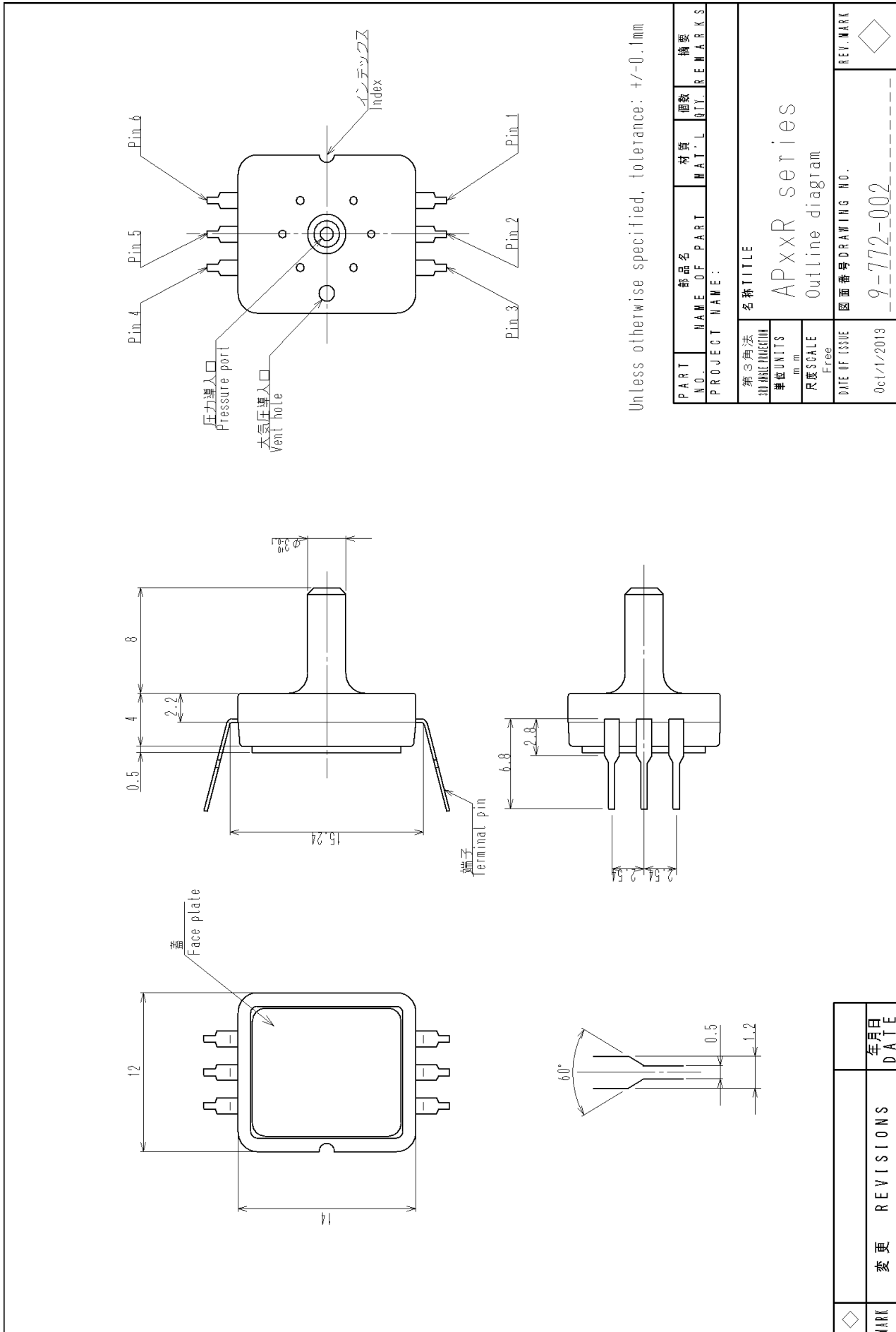

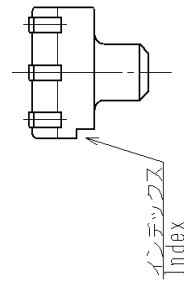
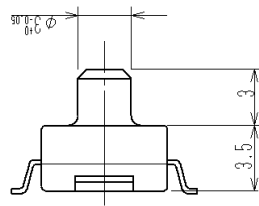
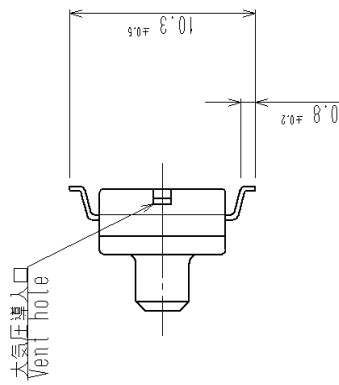
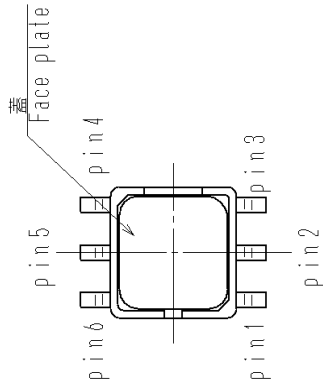
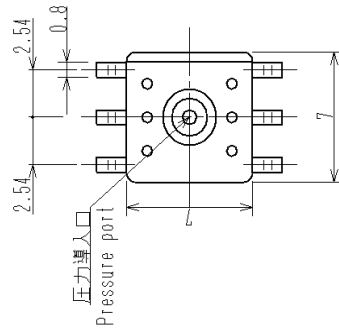

Unless otherwise specified, tolerance: +/-0.1mm

PART NO.	部品名	材質	個数	摘要
PROJECT NAME:	NAME OF PART	MAT'L	QTY.	REMARKS
名称 TITLE				
AGxx3 series				
Outline diagram				
第3角法 ANGLE METHOD				
単位 UNITS				
mm				
尺度 SCALE				
Free				
DATE OF ISSUE	図面番号 DRAWING NO.			REV. MARK
0ct/1/2013	9-772-003			◇

MARK	変更 REVISIONS	年月日
		DATE

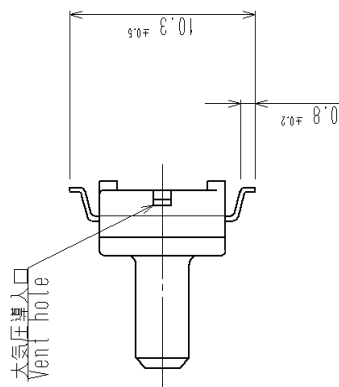
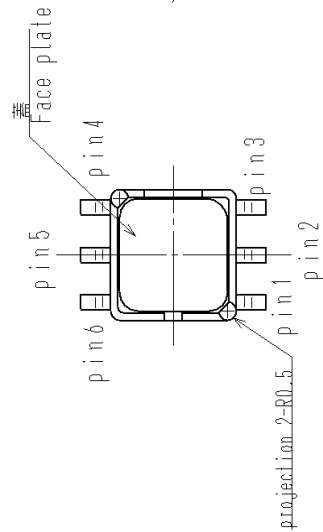
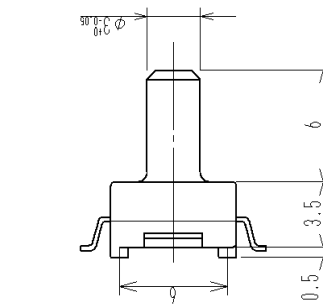
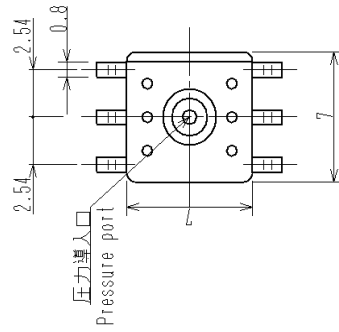

Unless otherwise specified, tolerance: $\pm 0.1\text{mm}$

PART NO.	部品名	材質	個数	摘要
INDEX	NAME OF PART	MAT'L	QTY.	REMARKS
PROJECT NAME:				
名称 TITLE				
AGxx6 series				
Outline diagram				
図面番号 DRAWING NO.				
9-772-004				
REV. MARK				
◇				

◇	MARK	変更	REVISIONS	年月日	DATE

Headquarter Switzerland:
Angst+Pfister Sensors and Power AG

Thurgauerstrasse 66
CH-8050 Zurich
Phone +41 44 877 35 00
sensorsandpower@angst-pfister.com

Office Germany:
Angst+Pfister Sensors and Power
Deutschland GmbH
Edisonstraße 16
D-85716 Unterschleißheim
Phone +49 89 374 288 87 0
sensorsandpower.de@angst-pfister.com



We are here for you. Addresses and Contacts.

Sales Germany & Austria

Geometrical sensors
Other products

Kurt Stritzelberger
Phone +49 89 374 288 87 22
kurt.stritzelberger@angst-pfister.com

Pressure sensors
Other products

Gerhard Vetter
Phone +49 89 374 288 87 26
gerhard.vetter@angst-pfister.com

Gas sensors and modules

Peter Felder
Phone +41 44 877 35 05
peter.felder@angst-pfister.com

Sales Switzerland & Liechtenstein

Postcode 3000 – 9999

Basil Frei
Phone +41 44 877 35 18
basil.frei@angst-pfister.com

Postcode 1000 – 2999

Christian Mohrenstecher
Phone +41 76 444 57 93
christian.mohrenstecher@angst-pfister.com

Sales International Key Accounts

Peter Felder
Phone +41 44 877 35 05
peter.felder@angst-pfister.com

Sales Other Countries / Product Management

Pressure Sensors
Load Cells

Philipp Kistler
Phone +41 44 877 35 03
philipp.kistler@angst-pfister.com

Gas sensors
Gas sensor modules

Dr. Thomas Clausen
Phone +49 89 374 288 87 24
thomas.clausen@angst-pfister.com

Flow / Level / Medical products

Dr. Adriano Pittarelli
Phone +49 89 374 288 87 67
adriano.pittarelli@angst-pfister.com

Power supplies

Sebastiano Leggio
Phone +41 44 877 35 06
sebastiano.leggio@angst-pfister.com

Linear position sensors
Angle sensors

Eric Letsch
Phone +41 44 877 35 14
eric.letsch@angst-pfister.com

Accelerometers
Sensor elements

Christoph Kleye
Phone +49 89 374 288 87 61
christoph.kleye@angst-pfister.com

Drive technology
CH Postcode 5000 – 9999 / DE

Roman Homa
Phone +41 76 444 00 86
roman.homa@angst-pfister.com

Drive technology
CH Postcode 1000 – 4999 / AT / IT / FR

Christian Mohrenstecher
Phone +41 76 444 57 93
christian.mohrenstecher@angst-pfister.com

Harald Thomas
Phone +49 89 374 288 87 23
harald.thomas@angst-pfister.com